

DELISEP-SC1 - MACERATION & DEWATERING



Product Features

- ✓ Designed to optimize the area in waste room
- ✓ Vertical frame in stainless steel AISI 304
- ✓ Large vacuum thermoformed feed hopper in black ABS with two magnets to block any accidental drop of ferrous metallic elements
- ✓ PLC control panel with customized running software
- ✓ Grinding system in stainless steel
- ✓ Pull-out hand hose spray for keeping the unit cleaned
- ✓ Unit delivered with marine feet



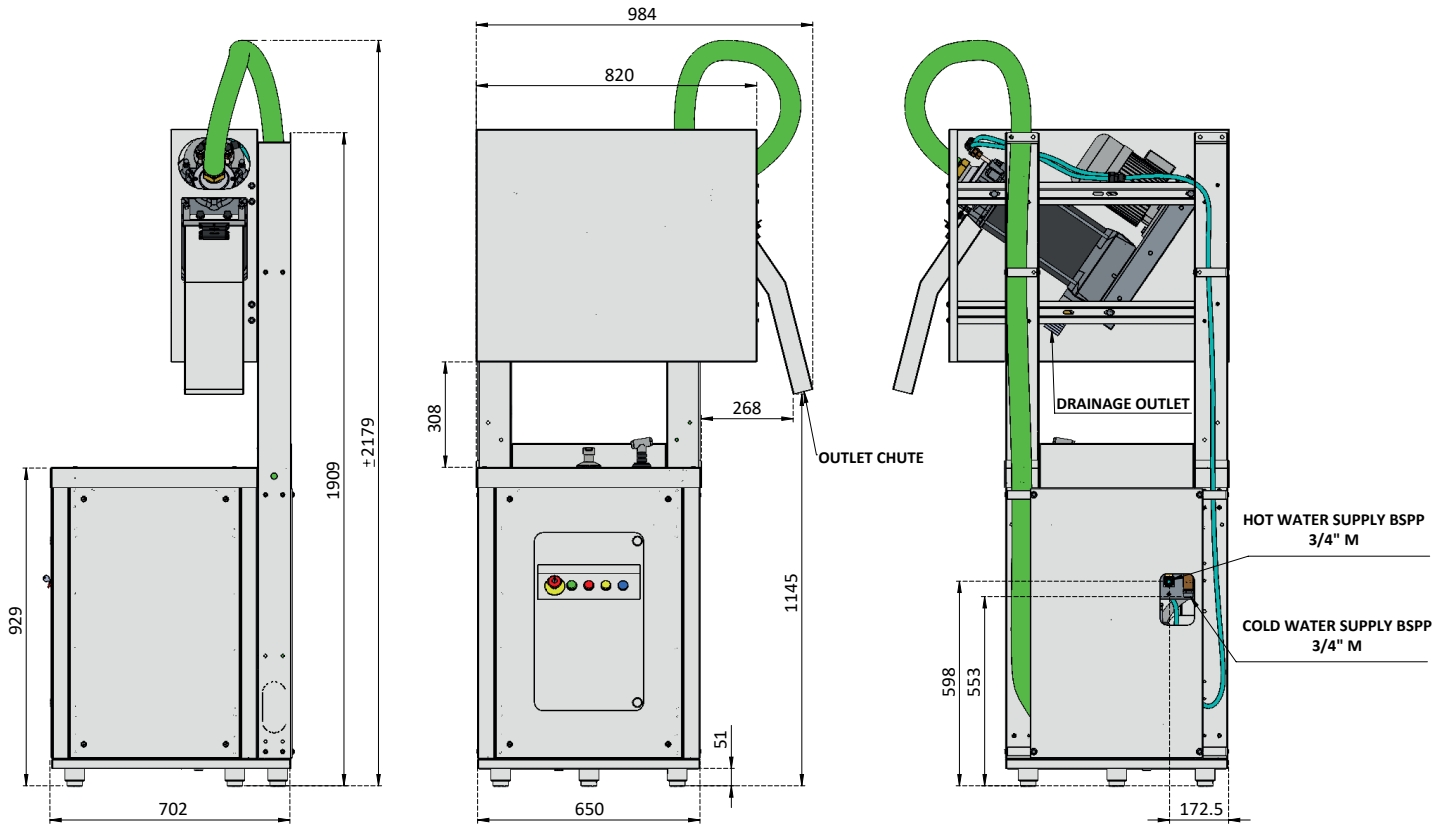

Technical specification

| | |
|------------------------------------------------------|------------------------------------------------------------------------|
| <i>Dimensions (DxWxH)</i> | 984x702x2179 (max) |
| <i>Weight</i> | 240 kg |
| <i>Macerator motor</i> | 2,2 kW (3 hp) - 3 ph 1430 RPM |
| <i>Impeller pump motor</i> | 0,75 kW (1 hp) - 3 ph 2810 RPM |
| <i>Pump gear box ratio</i> | 7:1 |
| <i>Dewaterer motor</i> | 1,1 kW (1,5 hp) - 3 ph 910 RPM |
| <i>Total power supply</i> | 4,1 kW |
| <i>Electrical supply</i> | 400 V - 50 Hz |
| <i>Capacity (mixed food waste) Water consumption</i> | Up to 550 kg/h depending by food waste mix 12 l per minute at 3 bar |
| <i>Waste recycling container capacity</i> | 120 l |
| <i>Water connections</i> | 3/4" M |
| <i>Electrical plug</i> | CEE 400V / 16 Amp 4P (3P + G) |
| <i>Noise level</i> | 70 - 75 dB |
| <i>Controls</i> | 24 V |
| <i>Cutlery magnetic saver</i> | Standard - Di Serie |
| <i>Hand hose spray</i> | Standard - Di Serie |

Delitek AS (Head Office)

Anna Eriksens Vei 31 N-8432 Alsvåg, Norway Tel: +47 76 18 57 60
www.delitek.no

Fax: +47 76 18 57 60

e-mail: sales@delitek.no