

DELISEP S390 FOOD WASTE DISPOSER

“Waste management equipment for the demanding maritime and offshore industry that gets the job done efficiently, safely and in an environmentally responsible manner.”



The S390 unit incorporates a powerful 2.2kW heavy duty motor with cast stainless-steel cutting rotor and grinder making it the most powerful compact macerating unit on the market. It is recommended to connect the S390 unit to the D700 or D800 dewatering unit at a maximum distance of 5 meters.



MARINE



OFFSHORE



NAVY



CRUISE



YACHT



FISHING



ONSHORE

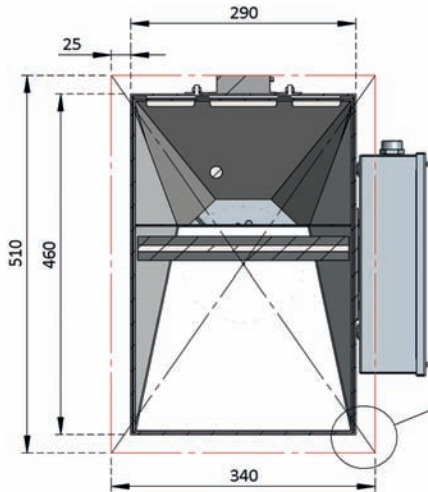

NOTE
 DIMENSIONS OF THE CUT-OUT IN TABLETOP FOR WELDED FITTING
 510 X 340 MM IT INCLUDES 25 MM ALLOWANCE ALL ROUND
 TO CLEAR FLANGE

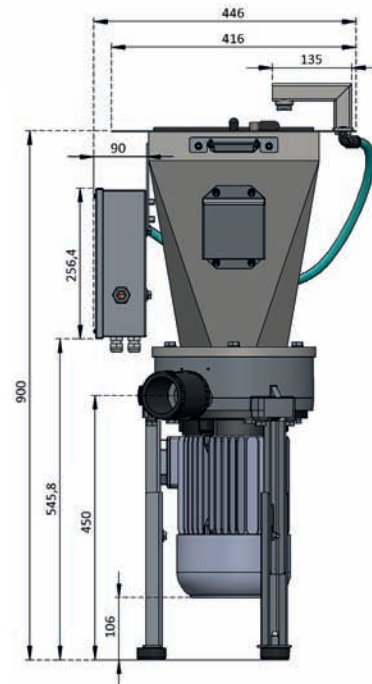
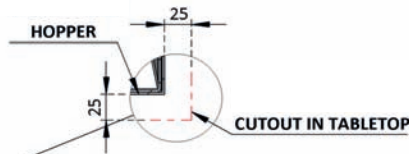

TECHNICAL SPECIFICATIONS

Macerator motor	kW 2,2 (3 hp) - 1430 rpm
Electrical supply	kW 2,2kW (3 ph) - 2800rpm -
Capacity (mixed food waste)	450 kg/h
Water consumption	12 l per minute at 3 bar
Noise level	73-75 dB
Drainage connections to	D700 - D800
Cutlery magnetic saver	Standard - Di Serie
Air-Break	Standard - Di Serie
Weight	70Kg

*All specifications are subject to change without notice.

Delitek AS (Head Office)

Anna Eriksens Vei 31 N-8432 Alsvåg, Norway Tel: +47 76 18 57 60 e-mail: sales@delitek.no www.delitek.no