

# DT-120C

## Densifier & baler version

**“Waste management equipment for the demanding maritime and offshore industry that gets the job done efficiently, safely and in an environmentally responsible manner.”**



DT-120C - Baler version

### KEY BENEFITS

- Stainless steel units for indoor or outdoor placement.
- Powerful electro/hydraulic drive for high press force.
- Delitek products are verified for marine and offshore use by DNV.
- For compaction and optional baling of cardboard, plastics, cans, tins etc.
- Will produce bales within 300mm x 300mm x 300mm size.
- Easy installation and operation (Plug & Play).



**MARINE**



**OFFSHORE**



**NAVY**



**CRUISE**



**YACHT**



**FISHING**



**ONSHORE**

## DT-120C

Material	Stainless steel AISI 304 or AISI 316
Loading opening (W x H)	269mm x 288mm
Compaction ratio	8:1
Compaction force (Max)	9 tons
Dimensions (W x D x H)	890mm x 393mm x 2313mm
Weight	180 Kg
Motor voltage	220V / 380~440V, 3Ph, 50~60Hz
Motor power	1,8 kW
Alternative power supply	Pneumatic
Noise level	<65dB Max

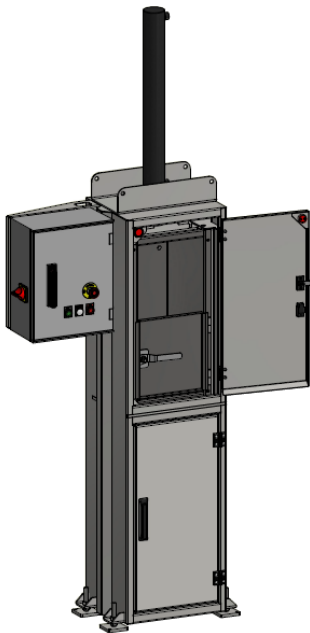

### Delitek AS (Head Office)

Anna Eriksens Vei 31  
www.delitek.no

N-8432 Alsvåg, Norway Tel: +47 76 18 57 60

Fax: +47 76 18 57 60

e-mail: sales@delitek.no