

## DELISEP D-700 DEWATERING UNIT

**“Waste management equipment for the demanding maritime and offshore industry that gets the job done efficiently, safely and in an environmentally responsible manner.”**



The D700 unit is incorporated in a small AISI 304 stainless steel cabinet, powered by a 1,1 kW motor. With body in stainless steel and cast anodized aluminum flanges this is one of the most powerful and compact dewatering unit on the market. The cabinet also includes the Liverani impeller pump, while the electrical panel and the button controls with IoT 4,3" touch screen are external and pre-wired.

It is recommended to connect the D700 unit to the S390 macerator unit at a maximum distance of 5 meters.



MARINE



OFFSHORE



NAVY



CRUISE



YACHT



FISHING



ONSHORE

### KEY BENEFITS:

- AISI 304 stainless steel stand-alone cabinet
- PLC control panel with controls & IoT Digital screen
- Compact dewatering unit
- Weight: 95 KG
- Removes excess liquid from macerated food waste through centrifugal action.
- Reducing the volume of the waste by up to 80%.
- Liverani Impeller pump.

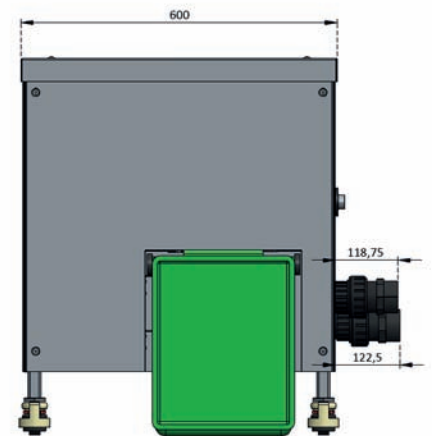
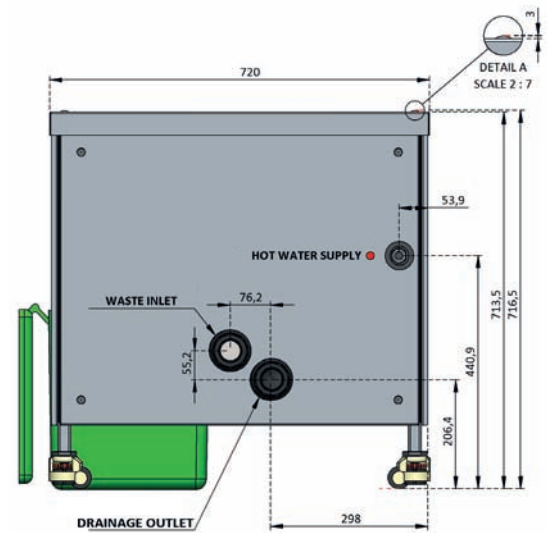

\*All specifications are subject to change without notice.

### TECHNICAL SPECIFICATIONS

Dewaterer motor	1,1 kW (1,5hp)
Impeller pump motor	0,75 kW (1 hp)
Pump gear box ratio	7:1
Total power supply	1,9kW
Electrical supply	400 V - 50Hz
Capacity up to	35 l. per minute
Hot water consumption for cleaning cycle	6 l per minute at 3 bar
Noise level	60-70 dB
Connected to	S390
Waste water pipe size	50 mm
Water connection	¾" male
Drainage outlet	50 mm
Bucket capacity	21 l
Electrical panel	External
Controls	External 24V
Electrical plug	CEE 400V 4P ( 3 P + G ) 16 Amp
Weight	95Kg

### Delitek AS (Head Office)

Anna Eriksens Vei 31 N-8432 Alsvåg, Norway Tel: +47 76 18 57 60

e-mail: sales@delitek.no www.delitek.no